

REV.	DESCRIPTION	DATE	BY

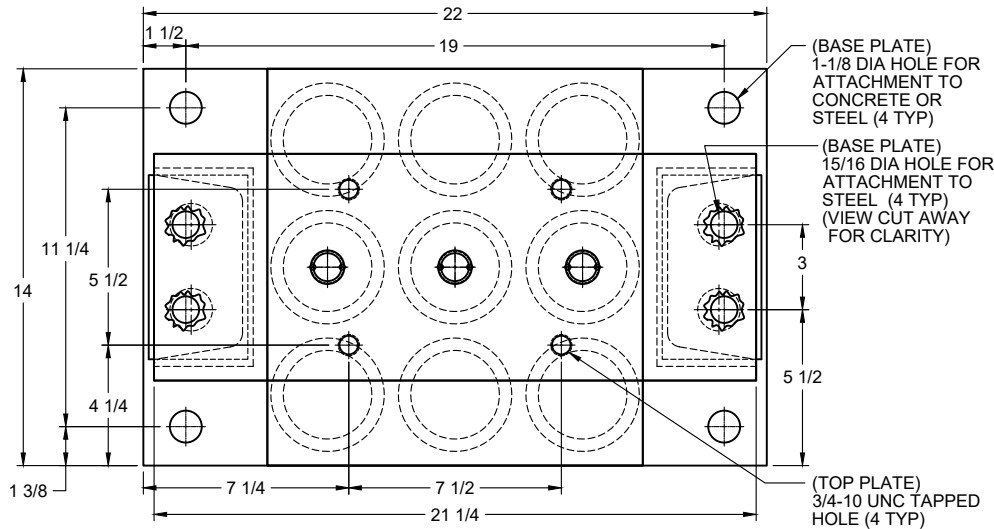

MODEL M9S-3C SEISMICALLY RESTRAINED VIBRATION ISOLATOR FOR 3" DEFLECTION				
SEISMIC MOUNT	RATED LOAD (LBS)	RATED DEFLECTION (IN)	SPRING RATE (LBS/IN)	COLOR CODE
M9S-3C-675	675	3.00	225	WHITE
M9S-3C-1305	1305	2.90	450	LT PURPLE
M9S-3C-1935	1935	2.59	747	LT BROWN
M9S-3C-2835	2835	2.37	1196	ORANGE
M9S-3C-4230	4230	2.35	1800	DK BROWN
M9S-3C-5400	5400	2.25	2400	DK PURPLE
M9S-3C-7740N ¹	7740	2.25	3440	ORANGE / RED
M9S-3C-9495N ¹	9495	2.34	4058	DK BROWN / RED
M9S-3C-10485N ¹	10485	2.25	4660	DK PURPLE / RED

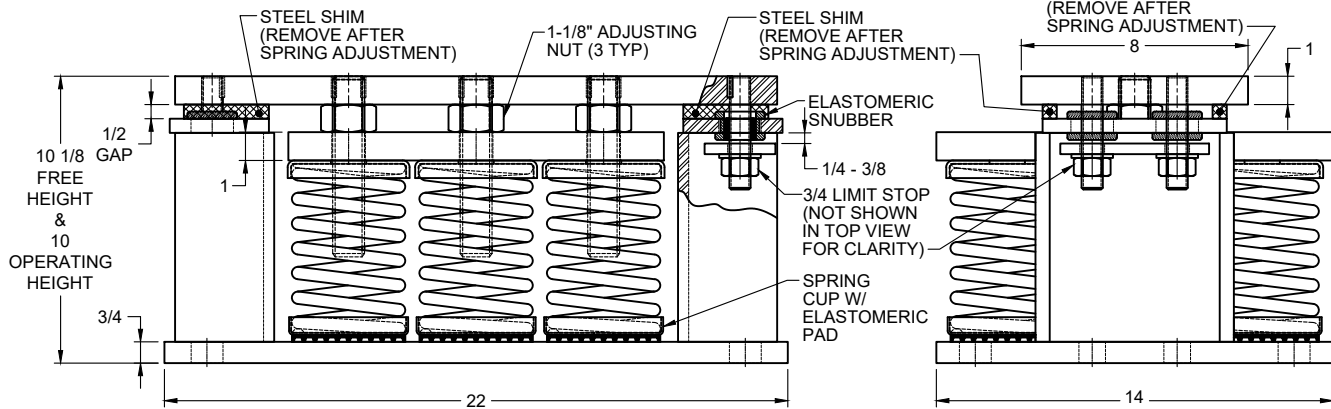

NOTE:
1. LOAD DETERMINED UTILIZING NESTED SPRINGS. THE COLOR CODE INDICATED IS FOR OUTER SPRING/INNER SPRING.

IF THE M9S-3C ISOLATOR IS BEING USED IN CONJUNCTION WITH THE M6S-3C AND/OR M4S-3C ISOLATOR(S), THE STANDARD M6S-3C / M4S-3C ISOLATORS CAN NOT BE UTILIZED.

PLEASE REFER TO THE FOLLOWING IN LIEU OF THE STANDARD:

- VMA-503357E - CUSTOM M4S-2E
- VMA-503357F - CUSTOM M6S-2E

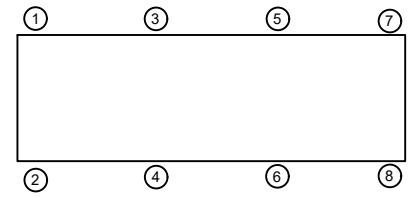

- NOTES:
1. ALL DIMENSIONS ARE IN INCHES, INTERPRET PER ANSI Y14.
 2. STANDARD FINISH: HOUSING - 1 COAT VMC STANDARD FINISH (COLOR:BLACK), SPRING - POWDER COAT (COLOR: SEE TABLE), HARDWARE ZINC-ELECTROPLATE.
 3. EQUIPMENT MUST BE BOLTED OR WELDED TO THE TOP PLATE TO MEET ALLOWABLE SEISMIC RATINGS.
 4. ISOLATOR BASE PLATE MUST BE ANCHORED TO CONCRETE WITH (4) 1" DIA. ANCHORS.
 5. ALL SPRINGS ARE DESIGNED FOR 50% OVERLOAD CAPACITY.
 6. REFER TO SHEET 2 OF 2 FOR INSTALLATION INSTRUCTIONS.
 7. RATED DEFLECTIONS ARE WITHIN 25% OF NOMINAL. HIGHER DEFLECTIONS ARE ALLOWED IF THEY MEET SPECIFICATIONS.
 8. ESTIMATED ISOLATOR SHIPPING WEIGHT: 250 LBS.
 9. MOUNT MAY BE SHIPPED PARTIALLY PRE-COMPRESSED.

ISOLATOR SELECTIONS	
LOC 1:	LOC 2:
LOC 3:	LOC 4:
LOC 5:	LOC 6:
LOC 7:	LOC 8:
CUSTOMER EQPT. TAG:	

NOTE: MATERIAL SHOWN IS FOR (1) SET.

OTHER MATERIALS, COMPOUNDS, OR FINISHES WITH EQUAL OR SUPERIOR PROPERTIES MAY BE SUBSTITUTED AS THEY BECOME AVAILABLE.

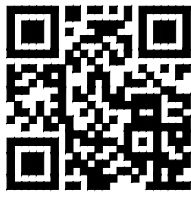

CERTIFIED FOR:

JOB NAME: _____

CUSTOMER: _____

CUSTOMER P.O.: _____

SALES ORDER: _____

MODEL M9S-3C-675 THRU -10485 LBS.
VIBRATION ISOLATOR WITH
INTEGRAL SEISMIC RESTRAINT
AND INTERNAL ADJUSTMENT
FOR 3 INCH DEFLECTION

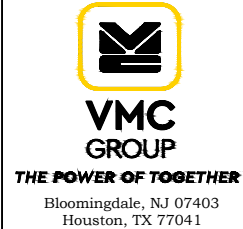

SCALE: NONE

SHEET: 1 OF 2

DRAWING NO.: _____

REVISION: _____

REV.	DESCRIPTION	DATE	BY

1. READ INSTRUCTIONS IN THEIR ENTIRETY BEFORE BEGINNING INSTALLATION.

- ISOLATORS ARE SHIPPED FULLY ASSEMBLED AND ARE TO BE POSITIONED IN ACCORDANCE WITH THE SUBMITTAL DRAWINGS OR AS OTHERWISE RECOMMENDED.
- SET ISOLATORS ON FLOOR, HOUSEKEEPING PAD, OR SUB-BASE, ENSURING THAT ALL ISOLATOR CENTERLINES MATCH THE EQUIPMENT MOUNTING HOLES. THE VMC GROUP RECOMMENDS THAT THE ISOLATOR BASE PLATES ("B") BE INSTALLED ON A LEVEL SURFACE. SHIM OR GROUT AS REQUIRED, LEVELING ALL ISOLATOR BASE PLATES AT THE SAME ELEVATION (1/4-INCH MAXIMUM DIFFERENCE CAN BE TOLERATED).
- ANCHOR ALL ISOLATORS TO THE FLOOR, HOUSEKEEPING PAD, OR SUB-BASE USING THRU HOLES ("C") FOR CONCRETE OR ("D") FOR STEEL AS REQUIRED. USE ANCHORS MEETING THE DESIGN REQUIREMENTS SPECIFIED ON SHEET 1 OF 2. WELDING TO STEEL IS PERMITTED PROVIDING THE WELD ACHIEVES THE REQUIRED STRENGTH.
- ISOLATORS ARE SHIPPED TO THE JOBSITE WITH (4) REMOVABLE SPACER SHIMS ("E") BETWEEN THE TOP PLATE AND THE HOUSING. THESE SHIMS **MUST** BE IN PLACE WHEN THE EQUIPMENT IS POSITIONED OVER THE ISOLATORS.
- WITH ALL SHIMS ("E") IN PLACE, PLACE THE MACHINE OR EQUIPMENT ONTO TOP PLATE ("A") OF THE ISOLATORS. BOLT EQUIPMENT SECURELY TO THE ISOLATORS USING MINIMUM ASTM A325 SAE GR. 5 HIGH-STRENGTH BOLTS, MEETING THE REQUIREMENTS (IF ANY) SPECIFIED ON SHEET 1 OF 2. WELDING IS PERMITTED PROVIDING THE WELD ACHIEVES THE REQUIRED STRENGTH.

- THE ADJUSTMENT PROCESS CAN ONLY BEGIN AFTER THE EQUIPMENT OR MACHINE IS AT ITS FULL OPERATING WEIGHT.
- BACK OFF EACH OF THE (2) OR (4) LIMIT STOP LOCKNUTS ("F") PER ISOLATOR 1/4 TO 3/8 INCH.
- ADJUST EACH ISOLATOR IN SEQUENCE BY TURNING ADJUSTING NUT(S) "G" ONE FULL CLOCKWISE TURN AT A TIME. REPEAT THIS PROCEDURE ON ALL ISOLATORS, ONE AT A TIME. CHECK THE LIMIT STOP LOCKNUTS ("F") PERIODICALLY TO ENSURE THAT CLEARANCE BETWEEN THE WASHER AND RUBBER GROMMET IS MAINTAINED. STOP ADJUSTMENT OF AN ISOLATOR ONLY WHEN THE TOP PLATE ("A") HAS RISEN JUST ABOVE THE SHIM ("E").
- REMOVE ALL SPACER SHIMS ("E").
- FINE ADJUST ISOLATORS TO LEVEL EQUIPMENT.
- ADJUST ALL LIMIT STOP LOCKNUTS ("F") PER ISOLATOR TO OBTAIN 3/8-INCH GAP. THE LIMIT STOP NUTS MUST BE KEPT AT THIS 3/8-INCH GAP TO ENSURE UNIFORM BOLT LOADING DURING UPLIFT (AS IN THE CASE WHEN A COOLING TOWER IS DRAINED).
- INSTALLATION IS COMPLETE.

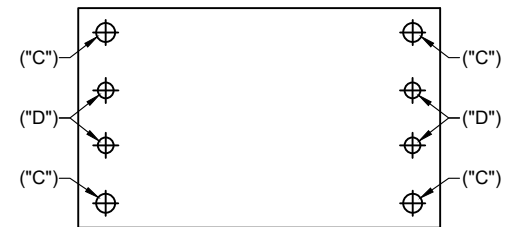
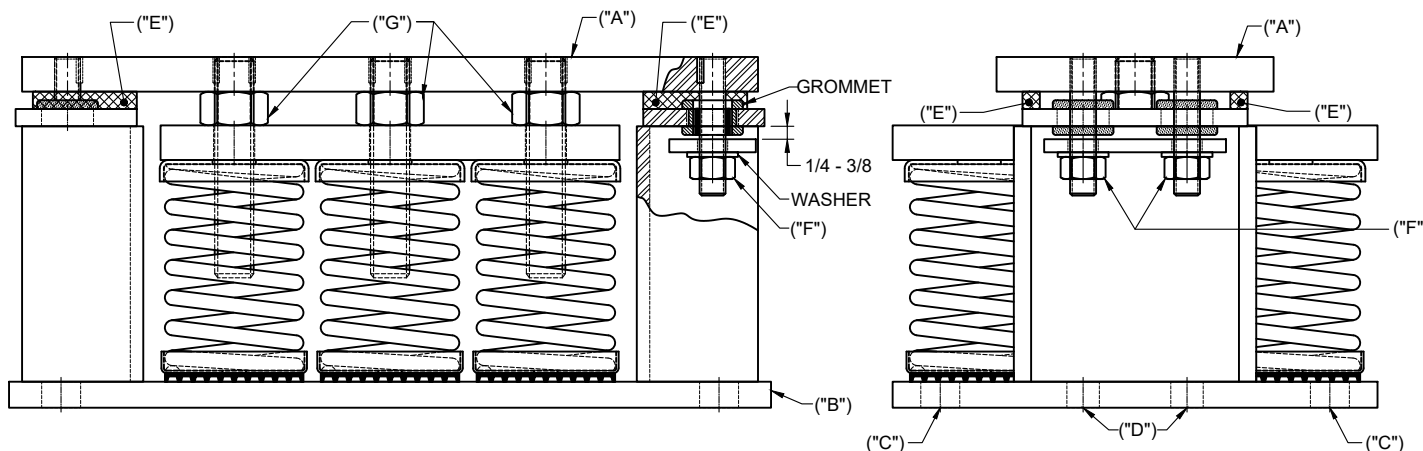

4 BASE PLATE HOLE LOCATION DIAGRAM
 NOTE: ISOLATOR BASE PLATE IS TO BE USED FOR HOLE LOCATION MARKING ONLY AND NOT AS A DRILLING GUIDE.

OTHER MATERIALS, COMPOUNDS, OR FINISHES WITH EQUAL OR SUPERIOR PROPERTIES MAY BE SUBSTITUTED AS THEY BECOME AVAILABLE.

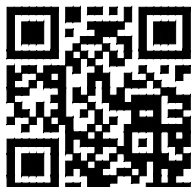

CERTIFIED FOR:

JOB NAME: _____
 CUSTOMER : _____
 CUSTOMER P.O.: _____
 SALES ORDER: _____

**MODEL M9S-3C-675 THRU -10485 LBS.
 VIBRATION ISOLATOR WITH
 INTEGRAL SEISMIC RESTRAINT
 AND INTERNAL ADJUSTMENT
 FOR 3 INCH DEFLECTION**



VMC GROUP
 THE POWER OF TOGETHER
 Bloomingdale, NJ 07403
 Houston, TX 77041

SCALE :
 NONE

SHEET:
 2 OF 2

DRAWING NO.: _____ REVISION

